

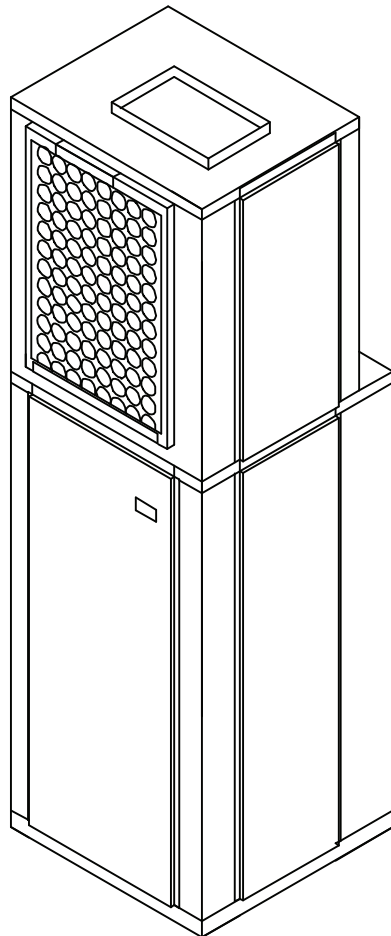

## Product Data

# 52VCR,VER,VQR,VWR09-24 Vertical Packaged Terminal Air Conditioners Cooling Only, Electric Heat, Heat Pump, or Hot Water Heat Units with PURON® Refrigerant (R-410A)

9,000 to 24,000 Nominal Btuh



The 52V Series vertical packaged units offer the following advantages:

- Completely pre-charged with Puron environmentally sound refrigerant (R-410A)
- Easy access for in-place service of most components
- Multi-function microprocessor board
- Completely insulated cabinet for sound attenuation and weather infiltration
- Adjustable fresh air damper
- Tool-less filter replacement
- Weight-supporting, single piece wall sleeves (except side access sleeves) for various wall thicknesses from 5 to 20-in.
- Primary condensate drain connection on sleeves with secondary overflow to building exterior
- All sleeves are shipped with a weather guard
- Flush type exterior architectural louvers

## Features/Benefits

**Carrier's 52V vertical packaged unit offers design flexibility, quality, reliability, and multi-function controls**

### **Solid-state circuit board**

The circuit board incorporates the following control features:

**Evaporator coil low temperature protection** protects the unit. During the cooling mode, should the evaporator coil experience either a low temperature condition that could result in ice build-up on the coil or a reduced airflow situation, a temperature sensor attached to the coil will deenergize the unit. The sensor will reenergize the unit when the coil warms up.



# Features/Benefits (cont)



**Low ambient lockout** locks out compressor at ambient temperatures below 40 F to extend compressor life.

**Random restart** is used when power is turned on after a power outage. A built-in random restart (3 to 4 minutes) prevents all the compressors from re-starting simultaneously.

**Compressor restart delay** of 3 minutes ensures that system pressures are allowed to equalize before a compressor restart, which extends compressor life.

**Front desk control** allows the user, when the unit is wired to a front desk console, to enable or disable each unit from the front desk, thus saving the energy used to condition unoccupied rooms.

**Fan delay** allows the evaporator blower to continue running for up to 45 seconds after the thermostat is satisfied. This feature maximizes cooling performance.

## Ease of service

A service pullout is factory installed for service convenience and maintenance.

Filter brackets and throwaway filter are shipped with each unit and are field installed over the unit's evaporator coil. Filter size is 18 x 24 x 1-inch.

## Adjustable operation

An adjustable fresh air (manual) damper can be used to meet code requirements for fresh air introduction. When opened, the fresh air vent allows up to 50 cfm of outside air to be introduced into the equipment closet. The air then mixes with return air entering the closet through the return-air grille. See Application Data section for more information.

## Thermostat control

The 52V unit is easily controlled by a standard low voltage wall-mounted thermostat instead of complicated unit-mounted controls. Low voltage wires are routed out the left side of the cabinet.

## Easy installation

Rear or side installation wall sleeves are provided for pre-installation. When ready, the 52V unit is simply slid into

the sleeve and the ductwork and electrical are connected.

The sleeve is weight-bearing and supports the entire weight of the 52V unit. The sleeve provides a weather tight seal against wind and water infiltration. A 3/4-in. male NPT fitting is provided in the bottom of the sleeve for field connection to a condensate riser.

Four wall sleeve depths are available to accommodate wall thickness from 5 to 20 inches. Each sleeve includes a factory-installed weather guard to cover the sleeve opening during construction.

## Unique sleeve drain condensate system

A factory-installed drain line connects the evaporator drain pan to a vertical pipe connection in the 52V basepan. Evaporator condensate is delivered from the unit to a catch tray in the wall sleeve and exits the sleeve through the 3/4-in. male NPT fitting.

This design allows the plumber to completely pipe the drain to a condensate riser during the pre-installation stage, thus decreasing the likelihood of condensate connection problems usually encountered when trying to connect the HVAC (heating, ventilation, and air conditioning) condensate drain to the riser after the HVAC unit is installed in the closet.

This feature also allows the 52V unit to be removed for service without

disconnecting the condensate piping. This configuration does not require any additional closet space to make the drain connection, as do some competitive products.

## Redundant systems

If for any reason the primary condensate riser becomes clogged, water will fill the catch tray and then be diverted through the sleeve to the exterior of the building, in a secondary system, rather than be allowed to overflow into the closet or living area. Rain water entering the sleeve is automatically diverted to the building exterior as well.

## Return air options

Ductable return air tabs are provided on the inlet of the evaporator coil to permit the connection of return air ductwork if required by local codes. Please note that most installations would not normally require ducted return air.

## Attractive appearance

The new flush-style architectural louver is an attractive extruded aluminum architectural louver that attaches to the outside face of the wall sleeve. The blades of the grille recess into the wall sleeve for a neat, flush appearance. Louvers install from the inside of the wall sleeve. The 52V unit should not be installed into the sleeve before installing the louver.

# Table of contents

	Page
Features/Benefits . . . . .	1-3
Model Number Nomenclature . . . . .	3
Capacity Ratings . . . . .	4,5
Physical Data . . . . .	5
Field-Installed Accessories . . . . .	6
Base Unit Dimensions . . . . .	7,8
Accessory Dimensions . . . . .	9
Performance Data . . . . .	10
Electrical Data . . . . .	11,12
Typical Wiring Schematic . . . . .	13
Controls . . . . .	14,15
Typical Installation . . . . .	16
Application Data . . . . .	17
Guide Specifications . . . . .	18,19

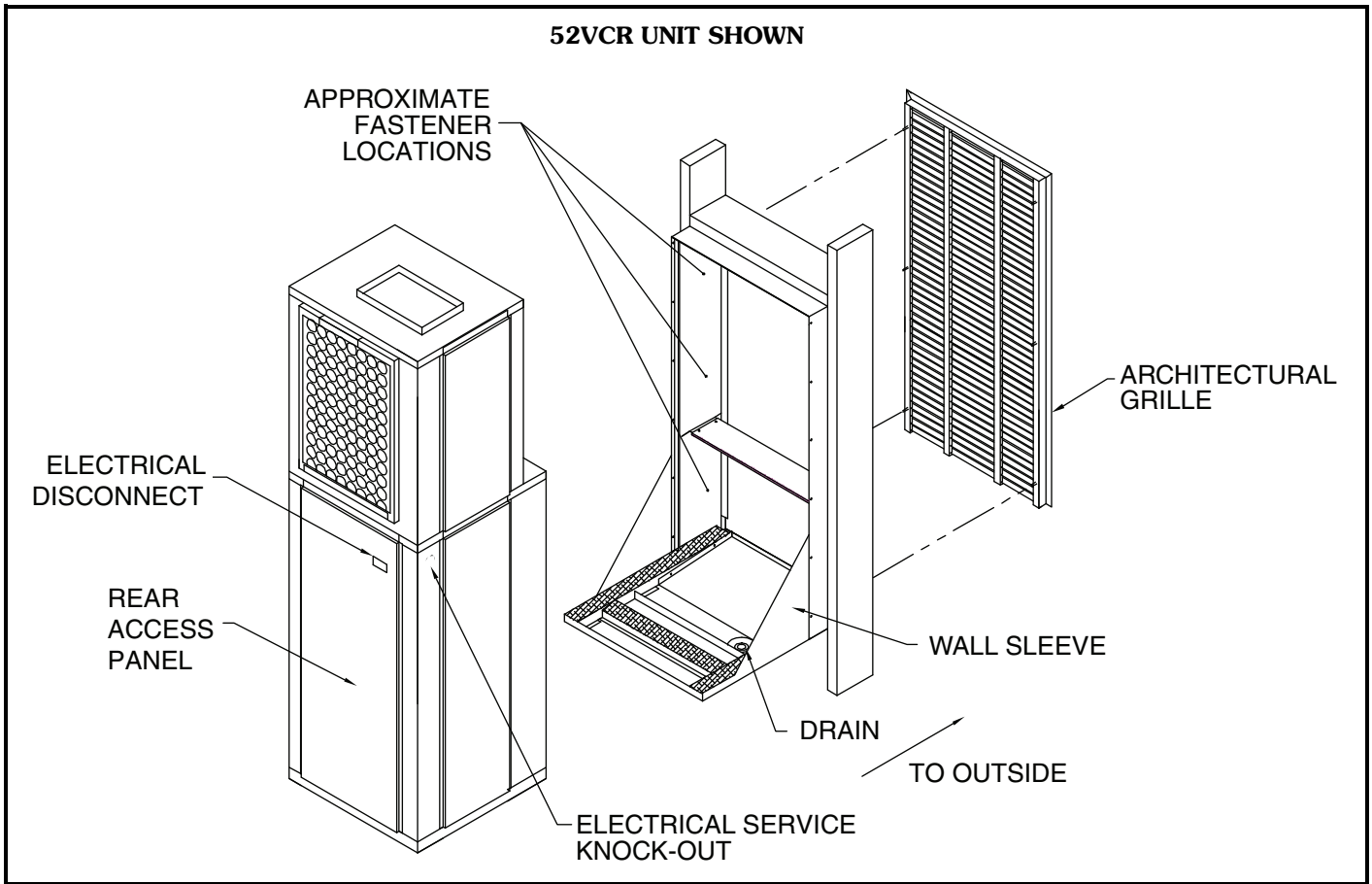

## Model number nomenclature

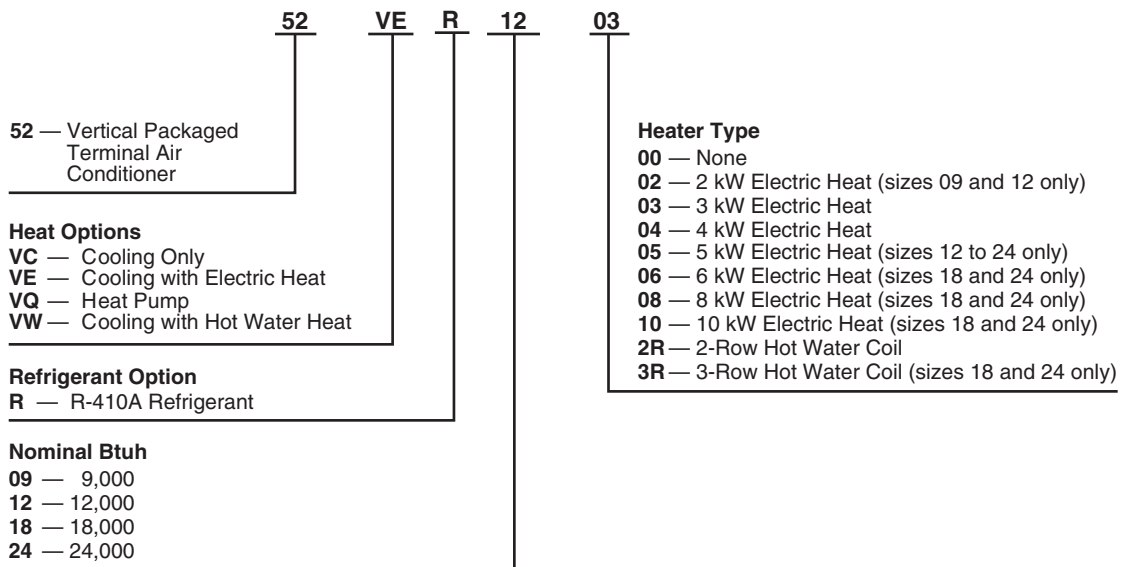

# Capacity ratings



## COOLING RATINGS — 52VCR COOLING ONLY, 52VER ELECTRIC HEATING, AND 52VWR HOT WATER HEAT UNITS

UNIT	COOLING CAPACITY (Btuh)	EER
52VCR,VER,VWR09	8,900	9.0
52VCR,VER,VWR12	11,500	9.0
52VCR,VER,VWR18	17,400	9.0
52VCR,VER,VWR24	21,500	9.0

**NOTES:**

1. Tested at 95 F/75 F WB outdoor and 80 F DB/ 67 F WB indoor.
2. Tested in accordance with AHRI (Air-Conditioning, Heating, and Refrigeration Institute) Standard 390.

## COOLING RATINGS — 52VQR HEAT PUMP UNITS

UNIT	COOLING CAPACITY (Btuh)	EER	COP
52VQR09	8,900	9.0	3.0
52VQR12	11,400	9.0	3.0
52VQR18	17,400	9.0	3.0
52VQR24	22,600	9.0	3.0

**LEGEND**

**EER** — Energy Efficiency Ratio

NOTE: Rated in accordance with AHRI (Air-Conditioning, Heating, and Refrigeration Institute) Standard 390. Ratings are net values, reflecting the effects of circulating fan heat. Ratings are based on:

**Cooling Standard:** 80 F db, 67 F wb indoor entering-air temperature and 95 F db, 75 F wb air entering outdoor unit.

## HEATING RATINGS — 52VQR HEAT PUMP UNITS

UNIT	HEATING CAPACITY (Btuh)
52VQR09	8,500
52VQR12	11,500
52VQR18	16,700
52VQR24	22,300

NOTE: Rated in accordance with AHRI (Air-Conditioning, Heating, and Refrigeration Institute) Standard 390. Ratings are net values, reflecting the effects of circulating fan heat. Ratings are based on:

**Heating Standard:** 70 F db, 60 F wb indoor entering-air temperature and 47 F db, 43 F wb air entering outdoor unit.

## ELECTRIC HEATER RATINGS — 52VER ELECTRIC HEATING AND 52VQR HEAT PUMP UNITS

UNIT SIZE	ELECTRIC HEAT DATA			
	kW		Btuh	
	230v	208v	230v	208v
52VER,VQR09	2	1.50	6,800	5,100
	3	2.25	10,200	7,700
	4	3.00	13,600	10,200
52VER,VQR12	2	1.50	6,800	5,100
	3	2.25	10,200	7,700
	4	3.00	13,600	10,200
	5	3.38	15,350	11,500
52VER,VQR18	3	2.25	10,200	7,700
	4	3.00	13,600	10,200
	5	3.38	15,350	11,500
	6	4.50	20,500	15,350
	8	6.00	27,300	20,500
52VER,VQR24	10	6.75	30,700	23,000
	3	2.25	10,200	7,700
	4	3.00	13,600	10,200
	5	3.38	15,350	11,500
	6	4.50	20,500	15,350
52VER,VQR24	8	6.00	27,300	20,500
	10	6.75	30,700	23,000

### HEATING RATINGS — 52VWR HOT WATER HEAT UNITS

UNIT	AIR FLOW (CFM)	GPM	PRESSURE DROP (in. wg)	BTUH (x1000) AT ENTERING WATER TEMPERATURE		
				120 F	140 F	180 F
52VWR12	500	4	3.2	12.7	17.8	28.0
		3	1.9	12.2	17.1	26.9
		2	0.9	11.5	16.1	25.3
	370	4	3.2	10.6	14.8	23.3
		3	1.9	10.2	14.3	22.5
		2	0.9	9.6	13.5	21.2
52VWR18 (2-Row Coil)	780	4	3.2	16.4	22.9	36.0
		3	1.9	15.7	22.0	34.6
		2	0.9	14.6	20.4	32.0
	690	4	3.2	15.3	21.4	33.6
		3	1.9	14.7	20.6	32.4
		2	0.9	13.6	19.1	30.0
52VWR18 (3-Row Coil)	760	4	4.7	21.1	29.5	46.3
		3	2.7	20.2	28.3	44.5
		2	1.3	18.8	26.3	41.3
	680	4	4.7	19.7	27.6	43.4
		3	2.7	18.9	26.5	41.6
		2	1.3	17.6	24.7	38.8
52VWR24 (2-Row Coil)	820	4	3.2	16.8	23.5	36.9
		3	1.9	16.1	22.5	35.3
		2	0.9	14.9	20.8	32.7
	590	4	3.2	14.0	19.6	30.8
		3	1.9	13.4	18.8	29.5
		2	0.9	12.6	17.6	27.6
52VWR24 (3-Row Coil)	800	4	4.7	21.7	30.4	47.8
		3	2.7	20.8	29.1	45.7
		2	1.3	19.2	26.9	42.3
	580	4	4.7	17.9	25.0	39.3
		3	2.7	17.1	24.0	37.7
		2	1.3	16.1	22.5	35.3

## Physical data

UNIT	SHIPPING WEIGHT (lb)			
	09	12	18	24
52VCR	245	245	255	255
52VER	245	245	255	255
52VQR	245	245	255	255
52VWR	—	245	255	255

# Field-installed accessories



**Wall sleeves** — Wall sleeves are available as a rear or side installation. The wall sleeve can be installed during construction and the unit installed at a later time. The sleeve can bear the entire weight of the 52V unit and provides a watertight seal against wind and weather. The condensate drain is built directly into the wall sleeve for pre-installation ahead of the unit. Four wall sleeve depths are available to accommodate wall thicknesses of 5 to 20 inches. A hurricane sleeve is available with a thicker, more durable construction for areas that may experience intense weather conditions. Each sleeve includes a factory-installed guard to cover the sleeve opening during construction.

**Exterior grilles (architectural louvers)** — The exterior grilles attach to the outside face of the wall sleeve and provide protection for the unit.

**Interior panel** — The interior panel is used for access to the unit installed in the closet. The panel is available as a louvered panel or a solid panel. The solid panel will result in lower sound levels. An external air grille and unit mount filter are required. The louvered panel allows air return into the closet to the unit and includes an 18 x 24 x 1-in. filter. Panels are shipped 10 per carton.

**Thermostats** — A complete line of thermostats is available to meet any control requirements. Thermostats are available in both horizontal or vertical layout types. Both cooling and electric/hot water heat thermostats (5 wire) and heat pump thermostats (6 wire) are available.

# Base unit dimensions

## 52VCR,VER COOLING ONLY AND COOLING WITH ELECTRIC HEAT UNITS

UNIT 52VC,VCR, VE,VER	DIMENSIONS (in.)	
	A	B
09,12,18	6 1/2	6 1/2
24	10	3

NOTE: Dimensions are in inches.

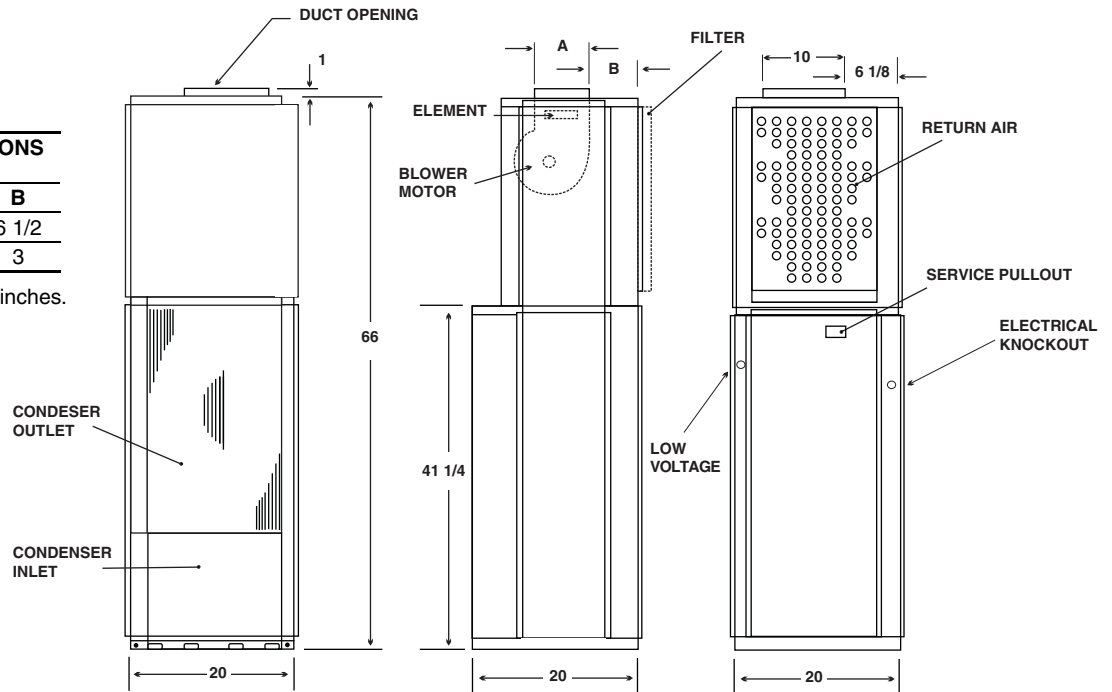

## 52VQR09-24 HEAT PUMP UNITS

UNIT 52VQ,VQR	DIMENSIONS (in.)	
	A	B
09,12,18	6 1/2	6 1/2
24	10	3

NOTE: Dimensions are in inches.

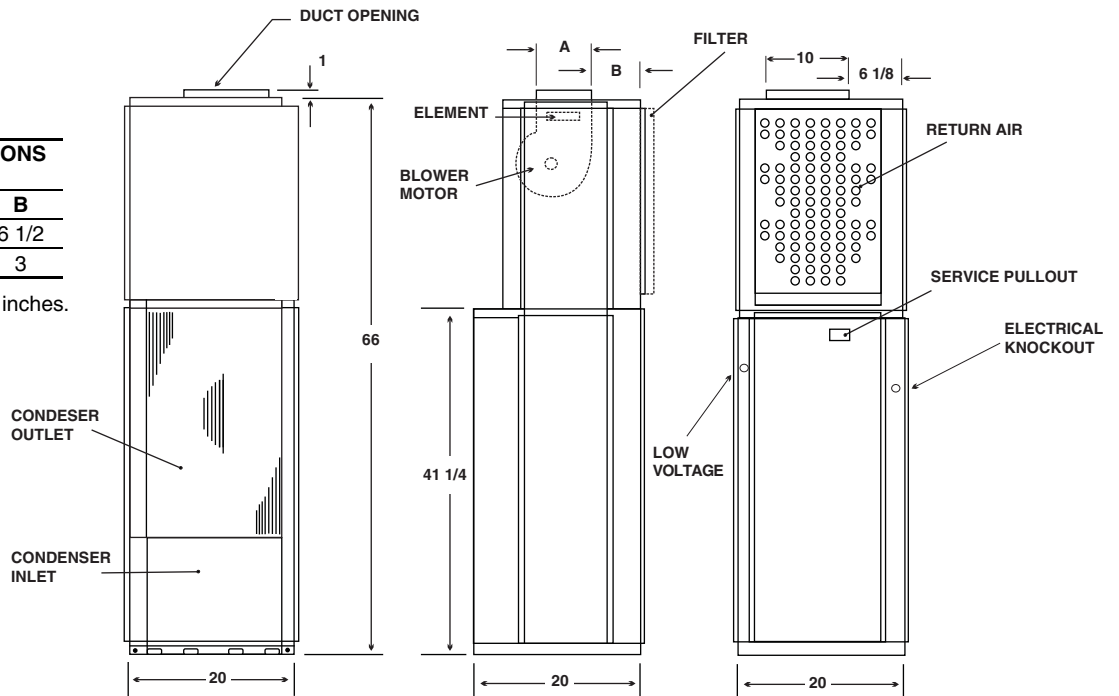

# Base unit dimensions (cont)

52VWR12-24 COOLING WITH HOT WATER HEAT UNITS

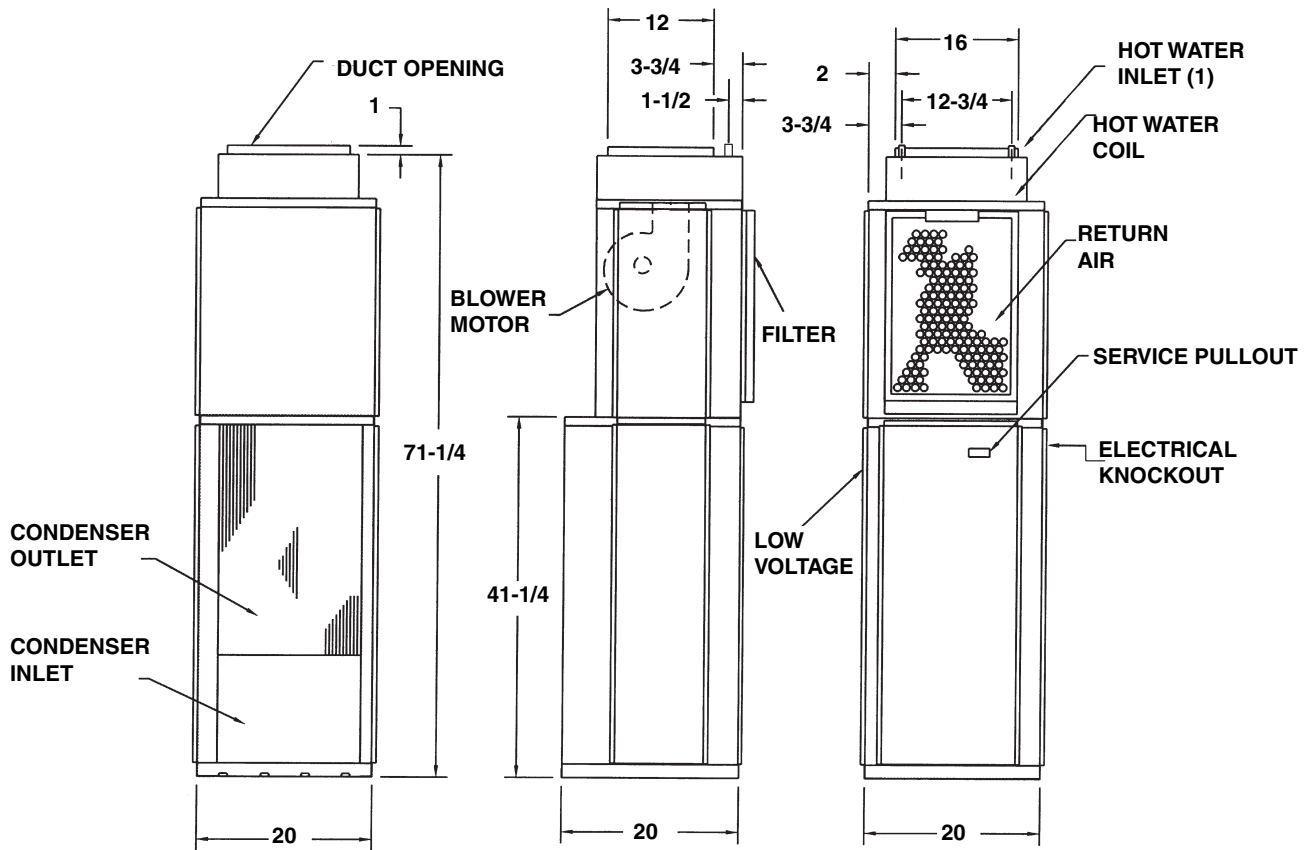

- NOTES:  
 1. Hot water coil connections are  $\frac{7}{8}$ -in. O.D. sweat.  
 2. Dimensions are in inches.



# Accessory dimensions

## INTERIOR PANEL

**PANEL DIMENSIONS (in.)**

PART NO.	A	B
52VX-LP-L (Louvered Panel)	87	84
52VX-SP-L (Solid Panel)		
52VX-LP-S (Louvered Panel)	82	79
52VX-SP-S (Solid Panel)		



## WALL SLEEVE AND EXTERIOR GRILLE

**WALL SLEEVE DIMENSIONS (in.)**

WALL THICKNESS	PART NO.	H	W	D	T
5-8 in.	52VX-SS-1	43 <sup>3</sup> / <sub>4</sub>	21 <sup>3</sup> / <sub>8</sub>	26	9
	52VX-RS-1				
	52VX-RH-1				
8-12 in.	52VX-SS-2	43 <sup>3</sup> / <sub>4</sub>	21 <sup>3</sup> / <sub>8</sub>	30	13
	52VX-RS-2				
	52VX-RH-2				
12-15 in.	52VX-SS-3	43 <sup>3</sup> / <sub>4</sub>	21 <sup>3</sup> / <sub>8</sub>	33	16
	52VX-RS-3				
	52VX-RH-3				
15-20 in.	52VX-SS-4	43 <sup>3</sup> / <sub>4</sub>	21 <sup>3</sup> / <sub>8</sub>	38	21
	52VX-RS-4				
	52VX-RH-4				

**LEGEND**

- RH** — Rear Installation Hurricane Sleeve
- RS** — Rear Installation Sleeve
- SS** — Side Installation Sleeve

**GRILLE DIMENSIONS (in.)**

PART NO.	H	W
52VX-SG-U	44	22
52VX-SG-L		
52VX-SG-C	45 <sup>3</sup> / <sub>8</sub>	22 <sup>3</sup> / <sub>4</sub>
52VX-HG-U		
52VX-HG-L		
52VX-HG-C		

**LEGEND**

- HG** — Hurricane Grille
- SG** — Standard Grille
- C** — Custom Paint
- L** — Prep for Paint Application
- U** — Anodized Aluminum

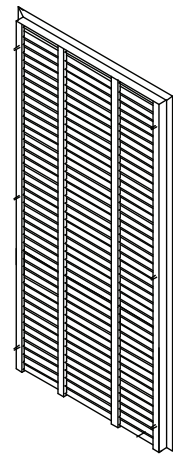
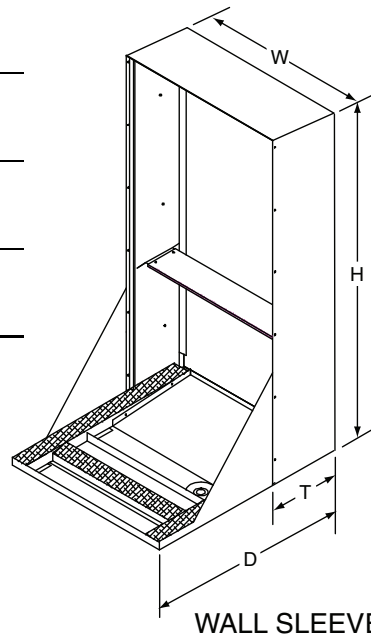

**WALL SLEEVE**

**ARCHITECTURAL GRILLE**

# Performance data



## FAN PERFORMANCE (CFM) — 52VCR,VER UNITS

UNIT SIZE	MOTOR SPEED SETTING*	EXTERNAL STATIC PRESSURE (in. wg)							
		0.05	0.10	0.15	0.20	0.25	0.30	0.35	0.40
09	HIGH	490	480	465	450	440	430	420	410
	MEDIUM	390	380	370	360	350	340	330	320
	LOW (C) (H)	310	300	290	280	270	260	245	230
12	HIGH	490	480	470	460	450	440	425	410
	MEDIUM (C)	400	390	380	370	360	350	335	320
	LOW (H)	310	300	290	280	270	260	250	240
18	HIGH	740	730	715	700	685	670	650	630
	MEDIUM (C)	670	660	645	630	615	600	585	570
	LOW (H)	560	550	545	530	515	500	485	470
24	HIGH	920	900	880	860	835	810	785	760
	MEDIUM (C)	870	860	850	840	820	800	775	750
	LOW (H)	760	750	740	730	720	710	700	690

\* This speed setting is hard-wired at the factory. To change the speed setting, the installer must rewire the terminals on the motor. An "H" next to the speed setting indicates the factory speed setting for heating

mode. A "C" next to the speed setting indicates the factory speed setting for cooling mode.

## FAN PERFORMANCE (CFM) — 52VQR UNITS

UNIT SIZE	MOTOR SPEED SETTING*	EXTERNAL STATIC PRESSURE (in. wg)							
		0.05	0.10	0.15	0.20	0.25	0.30	0.35	0.40
09	HIGH	490	480	465	450	440	430	420	410
	MEDIUM	390	380	370	360	350	340	330	320
	LOW (C) (H)	310	300	290	280	270	260	245	230
12	HIGH	490	480	470	460	450	440	425	410
	MEDIUM (C)	400	390	380	370	360	350	335	320
	LOW (H)	310	300	290	280	270	260	250	240
18	HIGH	740	730	715	700	685	670	650	630
	MEDIUM (C)	670	660	645	630	615	600	585	570
	LOW (H)	560	550	545	530	515	500	485	470
24	HIGH	920	900	880	860	835	810	785	760
	MEDIUM (C)	870	860	850	840	820	800	775	750
	LOW (H)	760	750	740	730	720	710	700	690

\* This speed setting is hard-wired at the factory. To change the speed setting, the installer must rewire the terminals on the motor. An "H" next to the speed setting indicates the factory speed setting for heating

mode. A "C" next to the speed setting indicates the factory speed setting for cooling mode.

## FAN PERFORMANCE (CFM) — 52VWR UNITS

UNIT SIZE	MOTOR SPEED SETTING*	EXTERNAL STATIC PRESSURE (in. wg)							
		0.05	0.10	0.15	0.20	0.25	0.30	0.35	0.40
12	HIGH (C)	510	500	490	480	465	450	435	420
	MEDIUM (H)	380	370	360	350	340	330	320	310
18 (2 Row Coil)	MEDIUM (C)	800	780	765	750	735	720	700	680
	LOW (H)	700	690	680	670	655	640	630	620
18 (3 Row Coil)	MEDIUM (C)	780	760	745	730	715	700	680	660
	LOW (H)	690	680	670	660	645	630	620	610
24 (2 Row Coil)	HIGH (C)	830	820	810	800	790	780	770	760
	MEDIUM (H)	610	590	575	560	545	530	520	510
24 (3 Row Coil)	HIGH (C)	810	800	790	780	770	760	750	740
	MEDIUM (H)	600	580	565	550	535	520	510	500

\* This speed setting is hard-wired at the factory. To change the speed setting, the installer must rewire the terminals on the motor. An "H" next to the speed setting indicates the factory speed setting for heating

mode. A "C" next to the speed setting indicates the factory speed setting for cooling mode.

# Electrical data



## 52VCR,VER UNITS (208/230 V-1 Ph-60 Hz)

UNIT SIZE	BLOWER DATA		CONDENSER DATA				ELECTRIC HEAT DATA				MCA		MOCP		
	Evaporator Motor		Compressor		Condenser Motor		Heater Type	kW		Total Heating Amps					
	Amps	Hp	RLA	LRA	FLA	Hp		230v	208v	230v	208v	230v	208v		
09	0.72	1/8	4.4	25	0.50	1/15	00	—	—	—	—	7	7	15	15
							02	2	1.5	6,800	5,100	10	12	15	15
							03	3	2.25	10,200	7,700	15	17	15	20
							04	4	3	13,600	10,200	19	22	20	25
12	0.72	1/8	5.6	29	0.72	1/10	00	—	—	—	—	9	9	15	15
							02	2	1.5	6,800	5,100	10	12	15	15
							03	3	2.25	10,200	7,700	15	17	15	20
							04	4	3	13,600	10,200	19	22	20	25
							05	4.5	3.38	15,350	11,500	22	25	25	25
18	0.87	1/8	6.5	43	0.72	1/10	00	—	—	—	—	12	12	20	20
							03	3	2.25	10,200	7,700	15	17	20	20
							04	4	3	13,600	10,200	19	22	20	25
							05	4.5	3.38	15,350	11,500	22	25	25	25
							06	6	4.5	20,500	15,350	28	33	30	35
							08	8	6.0	27,300	20,500	37	43	40	45
							10	9	6.75	30,700	23,000	42	48	45	50
24	2.8	1/3	9.9	54	0.74	1/8	00	—	—	—	—	17	17	20	20
							03	3	2.25	10,200	7,700	17	19	20	20
							04	4	3	13,600	10,200	21	24	25	25
							05	4.5	3.38	15,350	11,500	24	27	25	30
							06	6	4.5	20,500	15,350	30	35	30	35
							08	8	6.0	27,300	20,500	39	45	40	45
						10	9	6.75	30,700	23,000	44	50	45	50	

### LEGEND

- FLA — Full Load Amps
- HP — Horsepower
- LRA — Locked Rotor Amps
- MCA — Minimum Circuit Amps
- MOCP — Maximum Overcurrent Protection
- RLA — Rated Load Amps

# Electrical data (cont)



## 52VQR UNITS (208/230 V-1 Ph-60 Hz)

UNIT SIZE	BLOWER DATA		CONDENSER DATA				ELECTRIC HEAT DATA				MCA		MOCP		
	Evaporator Motor		Compressor		Condenser Motor		Heater Type	kW		Total Heating Amps					
	Amps	Hp	RLA	LRA	FLA	Hp		230v	208v	230v	208v	230v	208v		
09	0.72	1/8	4.4	25	0.50	1/15	02	2	1.50	6,800	5,100	10	12	15	15
							03	3	2.25	10,200	7,700	15	17	15	20
							04	4	3.00	13,600	10,200	19	22	20	25
12	0.72	1/8	5.6	29	0.72	1/10	02	2	1.50	6,800	5,100	10	12	15	15
							03	3	2.25	10,200	7,700	15	17	15	20
							04	4	3.00	13,600	10,200	19	22	20	25
18	0.87	1/8	6.5	43	0.72	1/10	05	4.5	3.38	15,350	11,500	22	25	25	25
							03	3	2.25	10,200	7,700	15	17	20	20
							04	4	3.00	13,600	10,200	19	22	20	25
							05	4.5	3.38	15,350	11,500	22	25	25	25
							06	6	4.50	20,500	15,350	28	33	30	35
							08	8	6.00	27,300	20,500	37	43	40	45
24	2.8	1/3	9.9	54	0.74	1/8	10	9	6.75	30,700	23,000	42	48	45	50
							03	3	2.25	10,200	7,700	17	19	20	20
							04	4	3.00	13,600	10,200	21	24	25	25
							05	4.5	3.38	15,350	11,500	24	27	25	30
							06	6	4.50	20,500	15,350	30	35	30	35
							08	8	6.00	27,300	20,500	39	45	40	45

LEGEND

- FLA — Full Load Amps
- HP — Horsepower
- LRA — Locked Rotor Amps
- MCA — Minimum Circuit Amps
- MOCP — Maximum Overcurrent Protection
- RLA — Rated Load Amps

## 52VWR UNITS (208/230 V-1 Ph-60 Hz)

UNIT SIZE	BLOWER DATA		CONDENSER DATA				MCA		MOCP	
	Evaporator Motor		Compressor		Condenser Motor					
	Amps	Hp	RLA	LRA	FLA	Hp	230v	208v	230v	208v
12	0.70	1/10	5.6	29	0.72	1/10	9	9	15	15
18	1.40	1/4	6.5	43	0.72	1/10	13	13	20	20
24	2.80	1/3	9.9	54	0.74	1/8	17	17	25	25

LEGEND

- FLA — Full Load Amps
- HP — Horsepower
- LRA — Locked Rotor Amps
- MCA — Minimum Circuit Amps
- MOCP — Maximum Overcurrent Protection
- RLA — Rated Load Amps

# Typical wiring schematic (52VER unit shown)

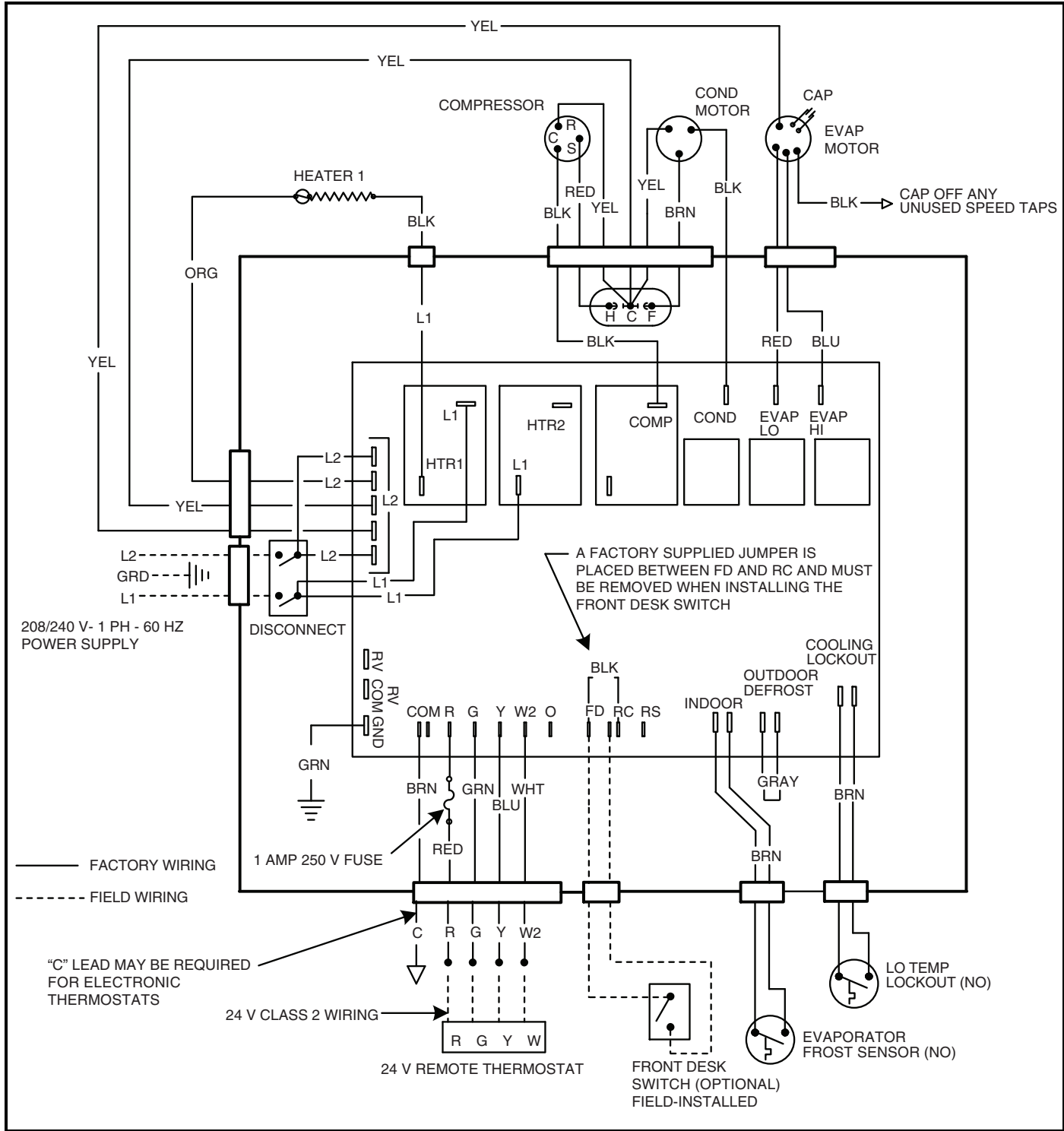

## Sequence of operation

### Start-up

The random time delay prevents any unit operation for 10 to 60 seconds after initial application of power to the unit.

The concurrent time delay prevents compressor and condenser fan operation for 3 minutes. This time delay also functions any time there is an interruption in the call for compressor operation.

NOTE: Additional time delays may be programmed into certain electronic thermostats.

When the thermostat fan switch is set to ON, the evaporator blower is energized.

NOTE: In either cooling or heating mode, if the thermostat is calling for operation of the compressor during the 3-minute time delay, the evaporator blower will not energize with the fan switch ON.

### Cooling

On a call for cooling, the condenser fan and evaporator blower are energized simultaneously. After 10 seconds the compressor will energize. All three functions are disabled if the 3-minute time delay is active. The unit will operate until the thermostat is satisfied.

When the thermostat is satisfied, the compressor and condenser fan will deenergize and the evaporator blower will continue to operate for an additional 45 seconds.

A temperature sensor (normally open) is installed on the suction line to interrupt the operation of the unit (in cooling mode only) in the event of limited airflow across the evaporator coil.

An outdoor ambient temperature sensor (normally open) is installed, which disables compressor and condenser fan operation when the outdoor temperature is below 40 F.

If the compressor is operating when the switch closes, the compressor will be allowed to operate until the thermostat is satisfied.

If the switch is closed (ambient temperature is less than 40 F), when the thermostat calls for cooling, then the compressor will not be allowed to operate and the indoor blower will operate until the thermostat is satisfied.

### Heating (electric and hot water heat)

On a call for heat, for electric heat and hot water heat units, the evaporator blower and the first bank of heating elements are energized and function until the thermostat is satisfied.

NOTE: Units with 5 kW or less of electric heat have only one bank of elements.

After 15 seconds, the second bank of heating elements is energized and functions until the thermostat is satisfied. Each bank of heating elements is equipped with a temperature limit, which will interrupt power to the heating element in the event of excessive temperature.

### Heating (heat pump units)

On a call for heating, the condenser fan and evaporator blower are energized simultaneously and after 10 seconds the compressor will energize.

NOTE: All three functions are disabled if the 3-minute time delay is active.

The unit will operate until the thermostat is satisfied.

Any time that power is applied to the unit and the thermostat is set to Heat or Auto, the reversing valve will be energized and in the heating position. If the room temperature is more than 2 degrees lower than the thermostat set point, then the electric heating elements will be energized and will operate until the difference between the set point and room temperature is less than 2 degrees.

NOTE: Any time that the thermostat calls for electric heat, the compressor and condenser fan will be locked out and will not operate until the electric heat is no longer called for. The 3-minute time delay is functional in this mode and will override the re-start of the compressor if it is active.

An outdoor ambient temperature sensor (normally open) is installed, which limits compressor and condenser fan operation when the outdoor temperature is below 40 F.

If the compressor is operating when the switch closes, the compressor will be allowed to operate until the thermostat is satisfied.

If the switch is closed (ambient temperature less than 40 F) when the thermostat calls for heat (Y1/W1), the compressor will not be allowed to operate and the electric heating elements will operate.

An outdoor coil temperature sensor (normally closed) is installed which is designed to interrupt compressor and condenser fan operation if the line temperature gets into a freeze up condition. Any time that this switch is activated and there is a thermostat call for heat, the unit will automatically switch to electric heat operation until the switch resets. A 6-hour time delay is set whenever the sensor interrupts the compressor operation. During this time delay any call for heat will bring on the electric heating elements.

## Thermostat specifications

**Fan operation** — Press the FAN button to select fan mode.

**Auto mode** — Fan will operate for 3 minutes minimum (trial fan period) to sample air temperature. If heating or cooling is not required, fan will turn off. Fan will remain inactive until heating or cooling become active.

**On mode** — Maintains constant fan operation.

**Economy mode** — Automatic economy function. Room temperature will be maintained between the economy heat (EH) activation temperature and the economy cool (EC) activation temperature. The LCD will appear blank. When room temperature rises 2 F above the EC activation temperature, the LCD will display the cool value and cooling symbol and activate cooling with fan.

When room temperature falls 2 F below the EH activation temperature, the LCD will display heat value and heating symbol, and activate heating with fan.

**Temperature selection** — Press UP or DOWN buttons to set temperature.

**Cooling** — Compressor (see Reversing Valve) and fan turn on automatically when temperature rises (see Deadband) above set point. Compressor has a 15-second delay before activation. After first cooling call, compressor and fan will turn on automatically when temperature rises above set point. Compressor will turn off when temperature drops below set point.

**Heating** — Compressor (see Reversing Valve) and fan turn on automatically when temperature drops below set point. Compressor will activate 15 seconds after fan turns on.

Auxiliary heat will become active only after the first 3 minutes of compressor operation. Once active, auxiliary heat will remain on until set point is satisfied or has operated for more than 3 minutes. Auxiliary heat will automatically turn on when temperature drops 4 F below set point.

After first heating call, compressor and fan will turn on automatically when temperature drops below set point. Compressor will turn off when temperature rises above set point.

**Deadband** — Deadband is active on start-up or initial heating or cooling requirement. When temperature is within 2 F of set point, the fan outputs will be off.

Fan operation will be as specified above.

Reversing valve will remain active.

**Reversing valve (heat pump only)** — Type B valves will energize in Heating mode. Reversing valve will turn on 15 seconds prior to heat/cool activity. Reversing valve will deenergize 3 minutes after compressor call. Reversing valve will remain inactive for cooling.

**Default mode** — For 75 to 90 seconds after power has been removed, the comfort set point (CS) of 72 F (program default) is automatically provided upon restoration of power. Default operating mode is Run mode. The default value can be restored by changing the scale.

**Diagnostic mode** — The Diagnostic mode may be invoked for maintenance purposes to verify thermostat performance. This mode is activated by holding the UP and DOWN arrow buttons for three seconds. The LCD will display fan operation, current cool or heat status, set point and room temperature.

To deactivate diagnostic mode, press the FAN button repeatedly or change scale with the slide switch.

**Scale change** — Move the slide switch to C to display Celsius. Move the slide switch to F to display Fahrenheit. Changing the scale will automatically reset the default comfort set point and run mode operation.

#### **Time delays**

- 3-minute delay (minimum) between Off and On
- 1.5-minute delay (minimum) between On and Off
- 3-minute delay (minimum) for auxiliary heat

# Typical installation

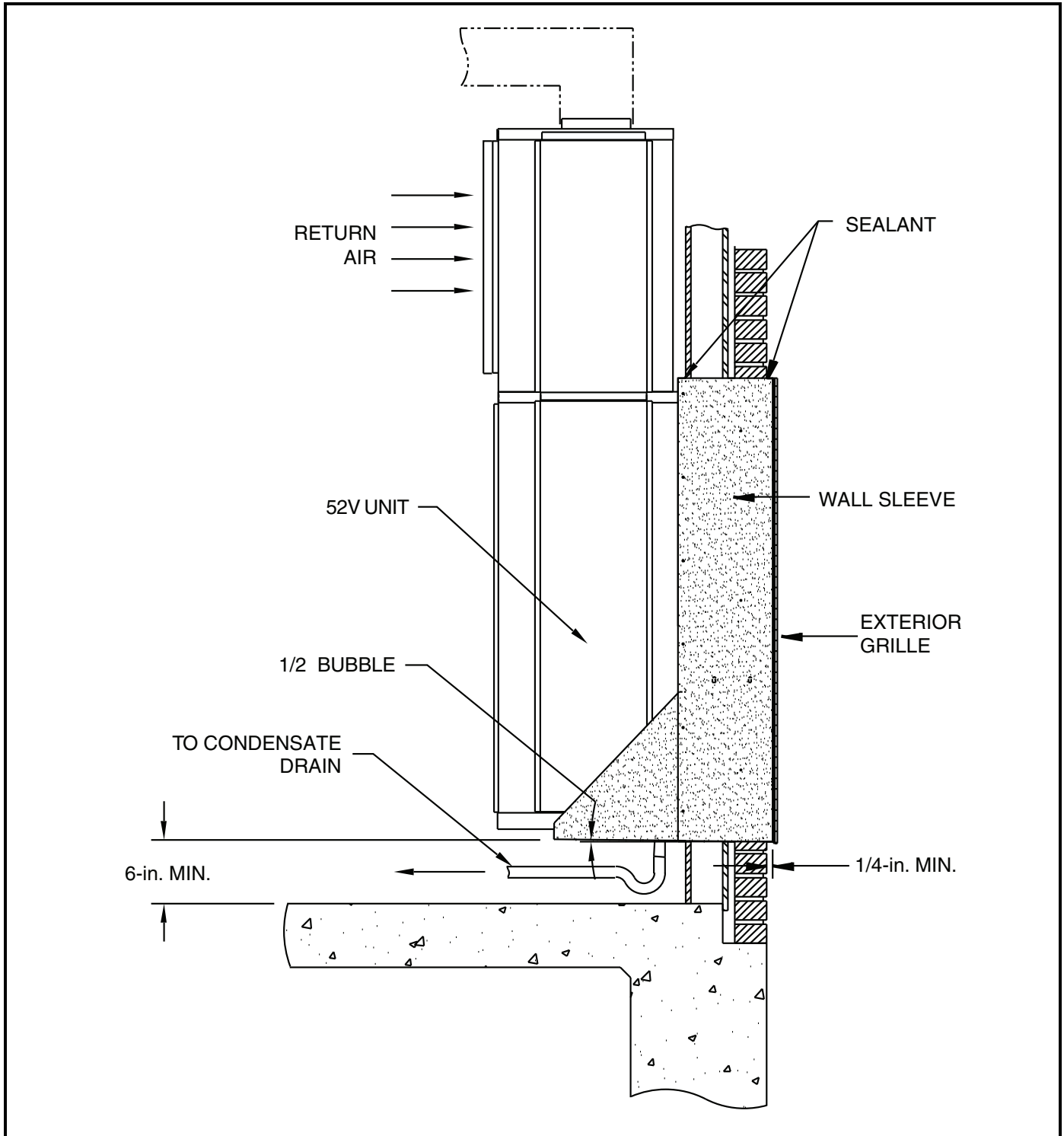



# Application data



## Location

Whether designing a new structure or replacing packaged terminal air conditioning units in an existing building, Carrier units can meet your needs in the following locations:

- Hotels and motels
- Nursing homes and assisted living care centers
- Offices
- Apartments
- Single-family dwellings
- Home conversions and residential add-ons

## New construction

The Carrier 52V vertical packaged terminal air conditioning (PTAC) unit is designed to meet the needs of the architect, engineer, and contractor. For unit installation, Carrier's expert support network will assist in all applicable aspects of the construction project, from preparing a budget to start-up.

## Advantages for new construction

Design flexibility for the architect/engineer:

- Whisper-quiet performance, indoors and out
- No bulky duct system
- No separate equipment room
- No water towers or additional cooling equipment
- No complex match-up of different HVAC components
- Less sensitivity to building orientation (sun, wind, shade)
- Optional architectural grille to permit custom exterior appearance

Initial cost savings for the building owner:

- No expensive component HVAC system to purchase
- No equipment room or maintenance engineering staff
- Weather-protected wall sleeve that goes in place during building construction (unit slides in place after construction is complete)
- No seasonal changeover required for cooling or heating

## Lower operating costs and reliable comfort for the occupant

- Heat pump models offer substantial savings over models with conventional electric resistance heaters
- Individual units allow tenants to choose the degree of comfort and operating economy
- Rapid servicing reduces downtime — complete chassis can be replaced in minutes without disrupting other occupants.
- Each unit operates independently of other units in the building. No dependency by building on central HVAC system.

## Sizing

Installation instructions are shipped with all PTAC units. It is important that air conditioning systems be properly sized and installed for each application in order to achieve the desired temperature and humidity levels within the space to be conditioned.

It is strongly recommended that a professional engineer match the PTAC units with the building structure and climate. The following application considerations are all

important in choosing the proper PTAC system for the building structure.

**Undersizing** — If a PTAC unit is undersized (cooling capacity is less than required capacity for an application), the unit will not be able to cool the space down to the desired temperature during very hot days. The result could be warm and humid or warm and dry conditioned space.

**Oversizing** — If a PTAC unit is oversized (cooling capacity is greater than required capacity for the specific application), the unit will cool the space down to the desired temperature too quickly. The unit will cycle on and off, however, dehumidification only takes place when the unit is operating. The result of this type of application in a hot and/or humid climate would be a cool, yet excessively humid, space.

**Air infiltration** — Excessive air infiltration can intensify problems associated with undersizing or oversizing a PTAC unit. This can be the cause of insufficient cooling, dehumidification, or heating. Sources of air infiltration include vents, gaps around windows and doors, and improperly sealed floors, ceilings or wall joints.

## Ventilation

A 4-in. aluminum vent pipe is connected to the condenser fan venturi and the side of the unit cabinet. A mesh screen is installed inside the vent pipe. A metal plate on the side of the cabinet covers the opening of the vent pipe.

Up to 50 cfm of fresh air can be introduced into the equipment closet by removing the metal cover plate. The fresh air then mixes with the return air and is pulled through the evaporator coil and into the supply duct.

The cover plate can be re-installed to partially close the fresh air opening if less than 50 cfm is desired. An external source of negative pressure (i.e., bathroom fan) could be used to introduce more than 50 cfm of fresh air if desired.

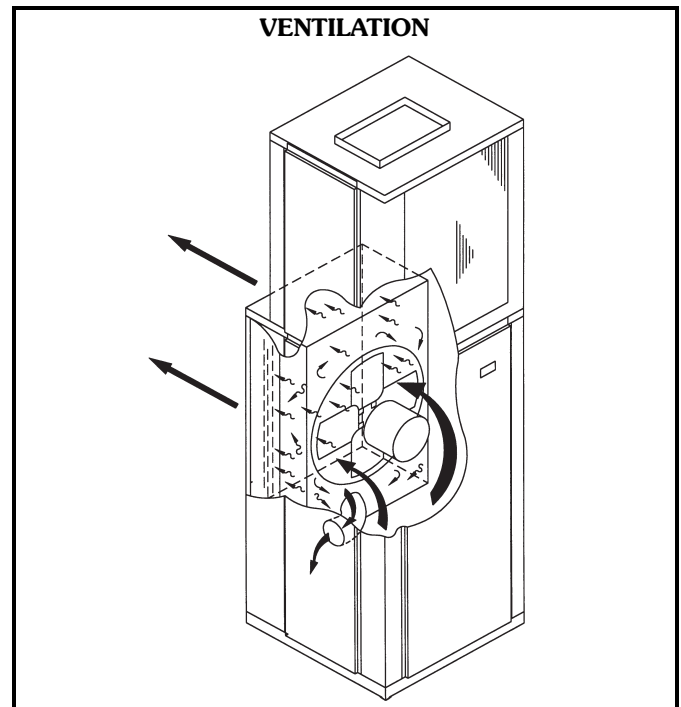

# Guide specifications



## Vertical Packaged Terminal Air Conditioners

### HVAC Guide Specifications — 52V

Size Range: **9,000 to 24,000 Nominal Btuh**

Carrier Model Numbers:

**52VCR (Cooling Only with R-410A Refrigerant)**

**52VER (Cooling with Electric Heat and R-410A Refrigerant)**

**52VQR (Heat Pump with R-410A Refrigerant)**

**52VWR (Cooling with Hot Water Heat and R-410A Refrigerant)**

### Part 1 — General

#### 1.01 SYSTEM DESCRIPTION

Packaged, self-contained, vertical through-the-wall air-cooled terminal heat pump with electric heat, straight cool with electric heat, or straight cool with hot water heat unit. Available with wall sleeve, room cabinet, electric refrigeration system, electric heating, outside-air grille. Fully charged with R-410A refrigerant and filled with oil.

#### 1.02 QUALITY ASSURANCE

System shall be approved and certified by UL. Chassis capacity and efficiency performance shall be rated in accordance with AHRI Standard 390, latest edition.

### Part 2 — Products

#### 2.01 EQUIPMENT

##### A. Electrical Characteristics:

1. Refer to schedule on drawings for electrical characteristics.
2. Disconnect switch shall be factory-installed on equipment.

##### B. Cabinet:

Cabinet shall be constructed of 20 gage galvanized steel, with removable front and side panels. Shall be fully insulated for sound attenuation and reduced air infiltration. Adjustable fresh air shall be available to meet code requirements for fresh air introduction. Removable front panels shall be provided for access to controls and unit.

##### C. Refrigeration System:

1. Direct expansion refrigeration cooling coil shall have  $\frac{3}{8}$ -in. OD high-efficiency rifled copper tubes mechanically bonded to high-efficiency aluminum fins. All coils shall be factory leak tested at 350 psig.
2. Hermetically sealed compressor with internal spring isolation, external isolation, permanent split capacitor motor and overload protection.
3. Accumulator (heat pump only).
4. Condenser coil and fan.

##### D. Air System:

Air system shall have centrifugal forward-curved evaporator fans with three-speed permanent split capacitor motor, optional filter grille.

##### E. Heating Coil:

1. Electric heating coil shall be 2 to 10 kW electric.
2. Hot water heating coil shall have  $\frac{3}{8}$ -in. OD high-efficiency rifled copper tubes mechanically bonded to high-efficiency aluminum fins. All coils shall be factory leak tested at 350 psig.

##### F. Condensate Drain:

Condensate drain shall be connected to a common drain riser. Should the main drain become plugged, the wall sleeve design shall divert the water to the outside of the building.

##### G. Condenser Fan:

Condenser fan shall be a propeller type with separate split capacitor motor.

##### H. Adjustable Fresh Air:

Outside air intake shall be adjustable to meet code requirements for fresh air introduction.

##### I. Wall Sleeves:

Wall sleeves shall be constructed of 20 gage galvanized steel to provide weathertight seal with disposable weather guard for installation and baked enamel finish inside and outside. Sleeve shall allow water to overflow front edge of sleeve if the primary drain becomes clogged.

##### J. Grille:

Grille shall be anodized corrosion-resistant aluminum, and custom painted.

##### K. Controls:

1. Control module shall be a remote thermostat with heat anticipator, heat-off-cool switch, on-auto fan switch.
2. Evaporator coil freeze protection shall be provided. During the cooling mode, should the evaporator coil experience freezing conditions that could result in ice build-up on the coil and subsequent compressor damage, a temperature sensor attached to the coil shall deenergize the compressor.
3. Low ambient lockout shall be provided to lock out compressor at ambient temperatures below 40 F to extend compressor life.
4. Random restart shall be provided. When power is turned on after a power outage, a built-in random restart (3 to 4 minutes) shall prevent all units from restarting simultaneously. Simultaneous restarting can damage electrical components.
5. Compressor restart delay shall be provided. A 3-minute delay shall ensure that system pressures are allowed to equalize before a compressor restart.
6. Fan delay shall be provided. In the cooling mode, the fan motor delay shall allow the fan to continue to operate up to 45 seconds after thermostat is satisfied.

L. Special Features:

1. A hurricane louver and hurricane wall sleeve shall be available for coastal areas.

2. A thermostat with adjustable high and low temperature limits shall be available.
3. Interior panel shall be available for field-installation as a louvered or non-louvered type.

